

Lerner Exoskeleton Actuators

Midpoint Report

18F26

Torki Alhaqan

Fawaz Almubarak

Mohammad Alali

Barjes Alenezi

Humood Aljabri

2018-2019



Department of Mechanical Engineering
Northern Arizona University
Flagstaff, AZ 86011

Project Sponsor: Northern Arizona University (Mechanical Department)

Faculty Advisor: Jason Luque

Sponsor Mentor: Zachary Lerner

Instructor: David Trevas

DISCLAIMER

This report was prepared by students as part of a university course requirement. While considerable effort has been put into the project, it is not the work of licensed engineers and has not undergone the extensive verification that is common in the profession. The information, data, conclusions, and content of this report should not be relied on or utilized without thorough, independent testing and verification. University faculty members may have been associated with this project as advisors, sponsors, or course instructors, but as such, they are not responsible for the accuracy of results or conclusions.

TABLE OF CONTENTS

Table of Contents

DISCLAIMER	2
TABLE OF CONTENTS	3
Table of Contents.....	3
1 BACKGROUND.....	1
1.1 Introduction.....	1
1.2 Project Description	1
1.3 Original System	1
1.3.1 Original System Structure.....	2
1.3.2 Original System Operation.....	2
1.3.3 Original System Performance	2
1.3.4 Original System Deficiencies.....	2
2 REQUIREMENTS	4
2.1 Customer Needs (CNs).....	4
2.2 Engineering Requirements (ERs).....	4
2.3 Testing Procedures (TPs)	5
2.4 House of Quality (QFD).....	6
3 EXISTING DESIGNS	7
3.1 Design Research.....	7
3.2 System Level.....	7
3.2.1 Existing Design #1: Sarcos exoskeleton	7
3.2.2 Existing Design #2: Berkeley exoskeleton.....	8
3.2.3 Existing Design #3: MIT exoskeleton.....	8
3.3 Functional Decomposition	9
3.3.1 Black Box Model.....	9
3.3.2 Functional Model/Work-Process Diagram/Hierarchical Task Analysis.....	10
3.4 Subsystem Level	10
3.4.1 Subsystem #1: Motors.....	10
3.4.2 Subsystem #2: ontrols	12
3.4.3 Subsystem #3: structure	13
4 DESIGNS CONSIDERED.....	14
4.1 Design #3: rotational spring.....	14
4.3 Design #7: springs connected to the pulley.	14
4.4 Designing of the exoskeleton using all the above designs.	15
5 Design Selected.....	16
5.1 The rationale for Design Selection	16

5.2	Design Description.....	16
6.0	Proposed Design	18
7	IMPLEMENTATION	19
7.1	Manufacturing.....	20
7.2	Design Changes.....	22
8	<i>Work Cited</i>	23
9	<i>Appendix</i>	24
9.1	Appendix A: Design Considered	24
i.	Design #1: Spring connected to cables.	24
ii.	Design #2: spring connected to plated leg.	24
iii.	Design #4: pulley or hip joint design.....	25
iv.	Design #5: damping spring design.....	26
v.	Design #6: buckling cables	26
vi.	Design #8: Design with straps.	27
vii.	Design #9: Fabric.....	29
9.2	Appendix B:	30

1 BACKGROUND

1.1 Introduction

The team looks into making improvements on the existing exoskeleton such that it could work better and more efficiently. The robotic exoskeletons are normally used by healthcare industries in order to assist people with neuromuscular disorders to be able to walk better than how they walk without the devices. The device has a system with motors that collaborate with the transmissions produced and give enough support to the ankle joints of the user [1]. Another aim of this project is to design a series elastic actuator that can assist the patient to have a more clinical gait and improve the walking movement. First, a new design of the exoskeleton is to be put in place. The previous form was not comfortable and came along with various difficulties. The new one is meant to set the record by enabling a stiff point of mounting on the user's organ, to be able to adjust to different sizes and ages of users, to be able to be easily put on and off, to be comfortable to the user as well as to be way lighter than the previous. Secondly, after making a design using springs in different ways that can help the patient not slip and walk more comfortable, then the project would have been successfully completed.

1.2 Project Description

The project entails the design, prototyping and manufacturing plan for an exoskeleton actuator system. The exoskeleton actuator can be classified as an electro-mechanical assistive technology that uses engineering and computing technologies to actualize the design of an artificial exoskeleton for use in assisting the disabled to walk again. Other uses of exoskeleton are to promote occupational safety and operability by enhancing the strength and safety of the wearer. In hospitals, the exoskeleton is used to assist people with neuromuscular disorders to walk and perform other functions that they cannot perform on their own. This is done by assisting their walking usually done when the device's system collaborates with its motors and the transmissions produced to support the movements of the ankle joints [1]. Most of the time, however, the exoskeleton is difficult to be mounted on the user's limb. This project, therefore, is meant to improve the existing exoskeleton to another design that can have the series elastic actuators implemented and successfully help the patient to achieve a no-slip walk and more comfortable movement and attach it to the exoskeleton in order to make the walking of the user easier than before.

1.3 Original System

There have been several iterations of an exoskeletal system for use as assistive technology to individuals with neuromuscular deficiencies. However, the original design was faced with various technical and operational challenges such as their excessive weights that ended up burdening users in other areas and hence exacerbating their conditions, others were not strong enough, there were also issues of low-quality built design and implementation, mismatched user and product requirements and functionalities, lack of adjustability and fluidity in response and operations, as well as a barrage of other operational, structural and mechanical deficiencies (Walsh 35). Such problems and deficiency are what promoted people to seek for more quality and custom fitted exoskeletons that are capable of meeting their individual needs with the only deterrent being the expensive nature of achieving such kind of modification and localization. There is, therefore, a need for investors and factory stakeholders to take into consideration the factors stated above in order for a higher level of customer satisfaction to be achieved

The original system comprised of a damping mechanism /system made up of springs, plates and a housing assembly. In the past, several designs were put in place so as to assist people living with neuromuscular disorders. The previous designs were greatly disadvantageous as they were; heavy for the user, weak, of poor quality, not able to be adjusted to the user's preference and not according to the user's demands [2]. These disadvantages propelled people to seek better ways to make and design the exoskeleton in order to eliminate the disadvantages. However, the new inventions were also more expensive and could not be afforded by everyone who required the devices. This project is meant to eliminate the disadvantages while also making the device more affordable to everyone. Therefore, the purpose of this project is to design a spring and choose the location to place it and have analytical data.

1.3.1 Original System Structure

The original system structure is designed to suit everyone no matter the age difference can able to use it. The robotic exoskeletons exist in different sizes; there are the big ones that are meant for adults, while there are smaller ones that are meant for little children [2]. They are normally strong, flexible and can be used for a long period of time thanks to the high-quality materials used in manufacturing them. The high-quality materials are used in order to make sure that the user is comfortable with the functioning of the device. Meaning that the exoskeleton is light and the chances of being injured are very low if an accident occurs. The exoskeleton is also designed such that the areas that touch the body have been made with soft materials in order to reduce friction and increase its comfort during walking [2]. In this way, the design of the exoskeleton meets all the user's expectations. Below is an example of the robotic exoskeleton.

1.3.2 Original System Operation

The original exoskeleton operated in two different ways, meaning that it was made in two different forms [3]. The first form was the one that was operated by the individual. This one is designed in a way that it contains an operating system fitted with sensors which enable the user to walk by guiding the movements of the limb. The second form is the one operated by someone else who is not the original user. This form of the exoskeleton is only allowed to be used when someone else is available in order to operate it while the user is moving. Despite their different forms, both of them function successfully when there are no disadvantages being experienced [3].

1.3.3 Original System Performance

The original system had a successful performance with very little disadvantages. The system is made with a design that it assists the user's limbs to move and also provides the user with energy for those that lack enough energy to move their muscles [2]. The system worked successfully and had been used in the past few years in order to improve the lives of individuals with neuromuscular disabilities. The system, however, needs to be upgraded in order to function well. This upgrading can be done by use of inventive technologies that emerge each day so as to make the exoskeletons more effective.

1.3.4 Original System Deficiencies

The original system had several disadvantages which this project tends to correct or improve on them. For instance, the materials used in the designing of the exoskeleton were responsible for its heavyweight thus causing the user to use most time trying to utilize the device without having to rest [3]. Furthermore, the way the limb was mounted on the exoskeleton was not always successful and therefore a better design should be invented in order to enable a tighter and a more effective grip. This means that the original system could not be adjusted, and the

users had to look for custom made exoskeletons which were far more expensive and time-consuming [2]. Some materials are also uncomfortable to the user as they tend to cause friction and irritation on the skin.

2 REQUIREMENTS

The team requires several customer requirements that are wanted by the client in order to look into the original system's disadvantages, search for ways to improve on them as well as work on improving the quality and function of the exoskeleton. These requirements can be compared to the requirements of engineers too.

2.1 Customer Needs (CNs)

The customer requirements are shown to be given by the client or stakeholders. Therefore, the team weighted the list of requirements and afterward set a target towards the improvement of the exoskeleton so as to be able to make a more efficient form of the exoskeleton

Table 1: Customer Needs

Customer Needs	Description
Measure torque	Measure the required torque in and out of the pulley and motor
Weight	The material of the exoskeleton
Spring location	The design of the best location of spring
Non-invasive	No contact of the ankle
Simple	Make the spring design as easy as possible

2.2 Engineering Requirements (ERs)

The engineering requirements are created by the team based on customer needs. It is imperative that item configuration engineers be comfortable with, and cling to, their organization's item measures and particulars, so they may structure quality items that speak to the organization mark. They should likewise remember patterns and the necessities of purchasers when planning items. Engineering requirements are derived from the customer needs and are more detailed according to engineering perspective. While engineers give a specialized arrangement, it is essential to comprehend that building configuration infers an answer that is stylish too. As it were, fashioners also are included to guarantee that the finished result is affordable, eco amicable and advances to clients. The team looked at the existing designs and their objectives. Since the previous design objectives were based on the consumer needs at that time, the team merged the modification proposal to the customer needs but at the same time making sure that the whole procedure would be under the recommended engineering standards like weight, dimensions and safety requirements. We opted for a compliant actuation, just as is the case in gait rehabilitation robot. In this kind of robot, there is need for substantial forces to help the patient. In the event of post stroke patients just the influenced leg must be bolstered while the development of the unaffected leg ought not be prevented. Not blocking the movements of one of the legs implies that mechanical impedance of the robot ought to be negligible (van der Kooij et al., pg 1). The blend of vast bolster forces and negligible impedances can be acknowledged by impedance or permission control.

Table 2: Engineering requirements

Engineering requirements	Description
Measure torque	0-7 Nm out of the motor 0-21Nm out of the lower pulley
Weight	Patient 50 lbs-150lbs
Spring location	design selection for the spring
Non-invasive	Make sure that metal bars and pulley system don't contact human ankle
Simple	Simple modular design that relies on separate but easy to assemble sections

2.3 Testing Procedures (TPs)

The main objective of testing the complete actuator was to determine whether the modification goal has been achieved and whether the product is viable. More so, testing is going to be check if the exoskeleton is working in line with the Engineering requirements.

1. Design Measure torque

The exoskeleton should have a torque out from the motor from 0-7Nm and the torque going out of the pulley will be 0-21 Nm this will depend on where spring is located.

2. Design a device with a weight limit.

This device should be able to accommodate the limb of a patient weighing from 50 to 150 lbs. to accomplish this requirement; individuals ranging from 50 all the way to 150 lbs. were tested on the exoskeleton. The feedbacks were analyzed, and it was noted that each and every individual was comfortable with the way the design was made on the exoskeleton.

3. Spring location

The team suggested three suitable locations to place the spring, then based on our analytical work we chose liner design spring.

4. Designing a more adjustable exoskeleton.

This was accomplished when the same individuals used to test on the weight limit were also used to test if the exoskeleton could be adjusted. In this case, the exoskeleton would be increased or decreased in size depending in the size of the individual's limb. The individuals also reported that the limb was comfortable despite the varying sizes. The limb could also be rotated at 180°.

5. Using of a softer fabric.

During the design of the exoskeleton, a softer fabric such as polyester was used so as to create comfort in the exoskeleton and to reduce the friction thus reducing chances of skin irritation. The fabric also helped in the reduction of the weight of the device. Therefore, after testing the device on individuals with varying ages and weight, it was discovered that the new design was far much better in terms of weight and comfort.

2.4 House of Quality (QFD)

QFD is House of Quality, which determines the relationship between the engineering requirements and customer requirements. Engineering requirements are the technical aspects of the project according to the client requirements and customer requirements are basically the project information provided by the client. As the Engineering requirements have developed from the customer requirements, therefore, it is necessary to make the relation between ER's and CR's and identify the effect of CR on ER. QFD is a matrix in which customer requirement and engineering requirement relate to each other and assign a value according to the importance in the corresponding matrix.

From the QFD, we obtained the targeted values of engineering requirements and determine the importance of each engineering requirement with the help of absolute technical importance and relative technical importance. QFD table is shown below in Table 3.

Table 3: QFD

Engineering Requirements	Importance	Provide Torque	Specify Material	Perfect location for spring	Must not contact with ankle	Not complicated design
		Customer Requirements				
Measured the required torque	9	9	3	1	1	1
Make the design lightweight	3		1	3	3	3
Make the people with disability walk normally	3	1		1	3	1
It must be non-invasive	1	3	1	3	1	3
It must be simple as possible	1	1	3	3	3	1
Technical Importance: Raw Score		88	34	27	31	25
Technical Importance: Relative Weight		42.9%	16.6%	13.2%	15.1%	12.2%
Technical Target Value		7	-	-	-	-
Units		Nm	-	-	-	-

From the above table, it is clear that the highest ranked engineering requirement is "Provide torque from 0 – 7 Nm and 0-21Nm which will be the torque out of the pulley" and the least important engineering requirement is "Not complicated design". It can see that provide torque has a raw value of 88 and RTI value of 42.9% whereas not complicated design has a raw value of 25 and RTI value of 12.2%. Research has shown that compliant actuators have an advantage in that they not just have a positive unsettling influence dismissal mode (through the consistence), yet in addition have adequate power following transmission capacity. The consistent actuators examined in this article were assessed for use in an exoskeleton for walk preparing reason yet might discover more extensive application. Most importantly the particular application will be

depicted, trailed by models and accomplished execution of the actuators. Therefore, when the needed motor torques will be high, actuator will not just have an ideal unsettling influence dismissal mode (through the consistence), yet additionally have adequate bandwidth.

3 EXISTING DESIGNS

Before the 1960s, people suffering from neuromuscular disorders had no way of improving their state. Thereafter, research groups located in the USA, as well as the former Yugoslavia, began researching on the human exoskeleton devices that could be powered [4]. The USA main research was however mainly on developing technologies that could be able to increase the functioning of normal people especially those in the military. On the other hand, Yugoslavia was mainly focused on developing the technology that could be able to help the physically handicapped [5]. Ever since the first design was made, other designs have always followed, the new version always being better than the previous in terms of effectiveness. The new developments were either meant to improve the previous designs or were completely new designs [4].

3.1 Design Research

In the past several years, various designs have been invented with the main purpose being helping those that are physically disabled on the lower part of the body, which is the limbs, to effect movement and other activities. The earlier designs created a platform for the team to look at and design a better exoskeleton. The team researched on the previous designs, on the internet and from scientific journals, and after coming up with an analysis the team learned of the issues that are related to the previous designs. This enables the team to come up with new ideas of designs as better analysis have been made. Apart from that, the team also searched up for more information in books and articles so as to create a better design of the exoskeleton. Since the invention and design of the first exoskeleton, there have been several improvements over the years that aim at producing a better product in terms of built functionality, quality and flexibility (adjustability). The proposed system that's under construction for this project was based on the apparent vulnerabilities and weaknesses/challenges of the existing exoskeletal systems. This design aims at achieving three main objectives; increased mobility. Increased flexibility and durability of the final product.

3.2 System Level

The original exoskeletons have always been the center of attention for a long time. Over the past 10 years, the exoskeletons have gone through three stages. The first one was being operated by an administrator as the base of the system. A good example of this is the Hardiman exoskeleton [3]. With time, inventions came up and individuals could be able to operate their own exoskeletons. The team analyses the combination of the various examples and then comes up with a more efficient design that exceeds the limitations of all the other previous exoskeletons.

3.2.1 Existing Design #1: Sarcos exoskeleton

This is an exoskeleton that can be used on the whole body. This exoskeleton contains a section that stores its energy for the functioning of the body. It produces the energy by use of the liquid medium. This helps as the liquid is found right where the joints that require support are [4]. The availability of the fluid medium allows the limb to rotate at an angle of 180°.



Figure1: Sarcos exoskeleton

3.2.2 Existing Design #2: Berkeley exoskeleton

This exoskeleton is mainly made for patients with neuromuscular disorders on the lower part of the body [4]. The system also moves with its own source of power. This exoskeleton is marked to be load bearing and would be very effective on patients with heavy weights. It is, therefore, suitable for patients from 50- 150 lbs.



Figure 2: Berkeley exoskeleton

3.2.3 Existing Design #3: MIT exoskeleton

1. This device works by learning the human walking style and then creates a mechanism of supporting the limbs thus making the human more comfortable as the weight of the exoskeleton is reduced. This exoskeleton depends on the energy that is in the springs when one walks [4]. This kind of exoskeleton is greatly similar to the team's project of spring invention. It also satisfies the need of accommodating the weight of the user, be it a child or a grown up.



Figure3: MIT exoskeleton

3.3 Functional Decomposition

The main purpose of this project is to design a series elastic actuation for a robotic lower extremity exoskeleton. The system will be actuated by a high-performance DC motor. Series elasticity will be implemented in the form of linear or rotational springs. In addition to the design and manufacturing of the system, the capstone team will provide the analytical characterization of system performance validated through experimentation.

3.3.1 Black Box Model

The original design was observed by the team and upon completion found to have difficulties with the functioning of the entire operating system. The team, therefore, looks into improving on the difficulties by use of a black box model. The black box model works by assisting the user's movement by creating coordination. This would be advantageous as the user would use less energy while moving faster. In this experiment, the team formed springs that can be attached to the exoskeleton. These springs are attached on the ankle. The main purpose of the springs is to be able to improve the design and functionality of the exoskeleton.

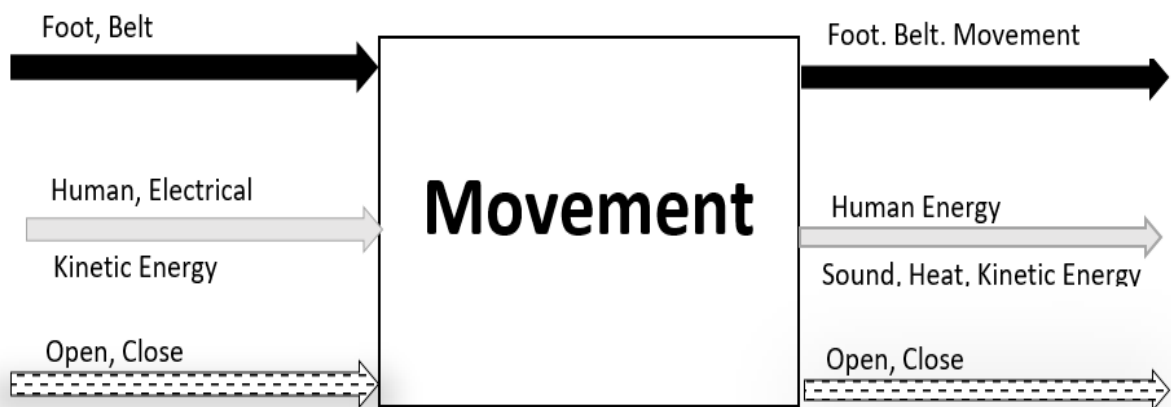

Figure4: Black Box

3.3.2 Functional Model/Work-Process Diagram/Hierarchical Task Analysis

In order to work well, the exoskeleton should be designed in such a way that the springs are located on the joints. In this case, it would be easier for the device to turn, retain its energy as well as support the user. In this case, springs are durable, unlike joints, they do not require greasing or much maintaining. Springs are also effective when it comes to reducing the weight of something. For instance, a heavy person would feel comfortable when using an exoskeleton with springs as the springs absorb shock in case of accidents. In this project, the team looks into designing a model that would generate its own energy and work effectively to satisfy the customers.

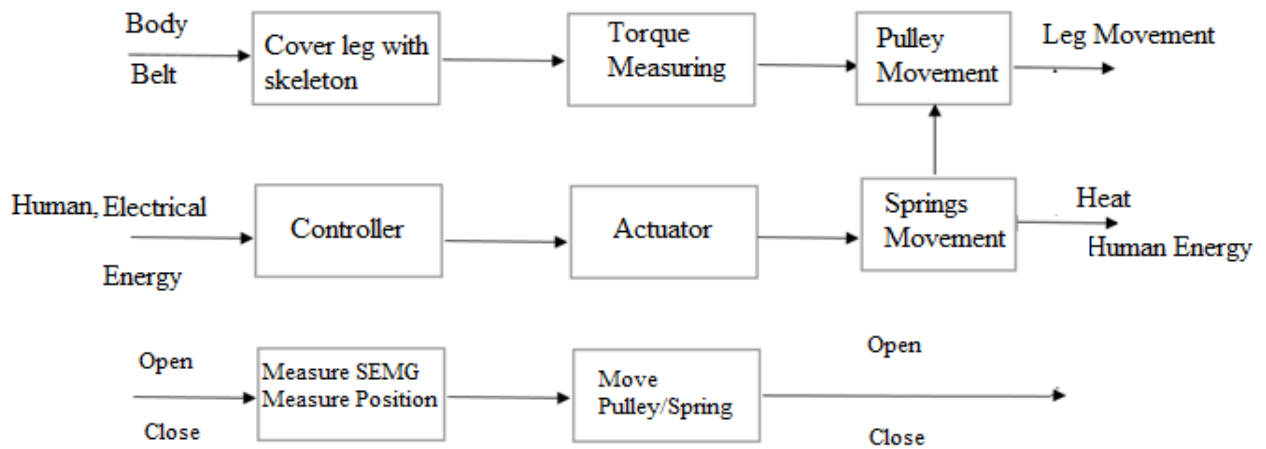

Figure5: Functional Model

3.4 Subsystem Level

In order to make the design effective, the components of the system should also be included [6]. The components are the ones that make up the entire system and when the team analyses the entire system's components then they get the perfect view of the efforts put in place to design the exoskeleton. In this case, the exoskeleton designed by the team will be perfect and satisfactory to the user [3]. This explains the reason as to while the subsystem is important too in the designing of the exoskeleton.

3.4.1 Subsystem #1: Motors

Motors support the movement of the joints and have been known to enable patients that are paralyzed to stand upright and walk. This helps to increase the quality of the exoskeleton.



Figure 1: exoskeleton motors

3.4.1.1 Existing Design #1: Sarcos exoskeleton

This exoskeleton utilizes energy produced by sensors that are located between the user and the exoskeleton [4]. In this case, the motors make it easier for the user to move as it supports the whole body and the liquid medium aids in movement of all the joints of the body. This exoskeleton utilizes energy produced by sensors that are located between the user and the exoskeleton [4]. In this case, the motors make it easier for the user to move as it supports the whole body and the liquid medium aids in movement of all the joints of the body. The Sarcos exoskeleton was built by military contractor Raytheon for use by the US military and is described as a wearable robotic suit used for increasing human agility, strength and endurance. The human, in this case, is a soldier on active duty such as a battlefield or providing relief effort during a natural catastrophe. The exoskeleton allows the wearer to easily lift heavy payloads at a ratio of almost 17:1. The result is the ability to repeatedly lift a given load without any injury or exhaustion to the wearer. The motor is hydraulically actuated. The system, however, incorporates a robot which is energetically autonomous. The system employs rotary hydraulic actuators as opposed to linear ones that are located on the system's power unit. The main disadvantage of the Sarcos exoskeleton is its bulky and heavy nature that ordinary users may find uncomfortable. Making it with smaller and thinner components may, however, allow for better functionality and may increase its popularity and acceptance by the civilian population.

3.4.1.2 Design #2: Berkeley exoskeleton

This exoskeleton is used by being mounted at the hip, knee and/ or the ankle. The motors are very efficient as they assist the lower body to function and even those who cannot walk completely have a chance of being able to move their limbs. The Berkeley exoskeleton unlike the Sarcos one is not full bodied and is only worn on the lower body. Its full name is the Berkeley Lower Extremity Exoskeleton (BLEEX) and its functionality just like the Sarcos one is to help soldiers to complement their strength through the addition of extra force to the lower extremity of the users. The system has two motors that are electrically actuated and located on the hips [8].

3.4.1.3 Existing Design #3: MIT exoskeleton

This exoskeleton has springs on the joint that flexes and extends. Combined with motors, the springs provide more energy and are sufficient for a longer period of time. The MIT exoskeleton, unlike the rest, is quite unique since it employs no motors for its operation. Instead, it relies on the principle of conservation of energy by using the user's weight and payload that they wear on their back and are attached to two similar leg-like springy mechanical structures that run parallel to the legs of the wearer. The structures or appendages possess elastic energy storage devices located at the hip and ankle as well as a damping device located on the knee. The spring-like joints are employed to harvest energy from the payload and user's motion and to store them for the next cycle of motion/ stride.

3.4.2 Subsystem #2: controls

This subsystem is responsible for the operation of the exoskeleton according to the need of the user. They can either be made according to the technology or the requirement of the user.

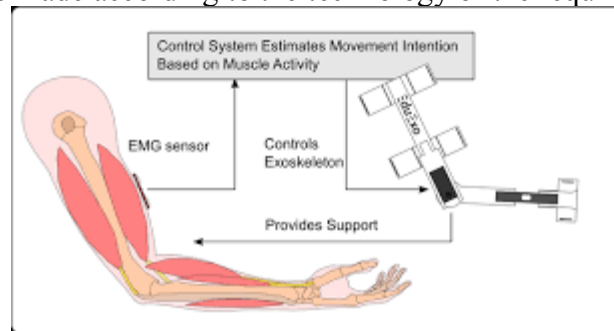

Figure 2: exoskeleton control

3.4.2.1 Existing Design #1: Sarcos exoskeleton

This exoskeleton is controlled by sensors that are located between the user and the exoskeleton. The team's project looks into coming up with a design that can be controlled by the user's movement to release energy.

3.4.2.2 Existing Design #2: Berkeley exoskeleton

The Berkeley exoskeleton is electronically actuated and is controlled by impulses generated from the movements of the wearer. This project looks to assimilate the same control system whereby the exoskeleton can provide enough energy to maintain the user's movements. This exoskeleton is used by being mounted at the hip, knee and/ or the ankle. The motors are very efficient as they assist the lower body to function and even those who cannot walk completely have a chance of being able to move their limbs. The Berkeley exoskeleton unlike the Sarcos one is not full bodied and is only worn on the lower body. Its full name is the Berkeley Lower Extremity Exoskeleton (BLEEX) and its functionality just like the Sarcos one is to help soldiers to complement their strength through the addition of extra force to the lower extremity of the users. The system has two motors that are electrically actuated and located on the hips [8].

3.4.2.3 Existing Design #3: MIT exoskeleton

Here, the energy is released during flexing and is stored during extending. Therefore, the exoskeleton is controlled by the joint movements. The project design will allow the exoskeleton to be controlled by the movement of the limb. The system is controlled through the movement of an individual's limb impulses.

3.4.3 Subsystem #3: structure

The subsystem does not only aid in the effective functioning of the exoskeleton, but it also helps with creating comfort for the user. Which are the most important aspects?

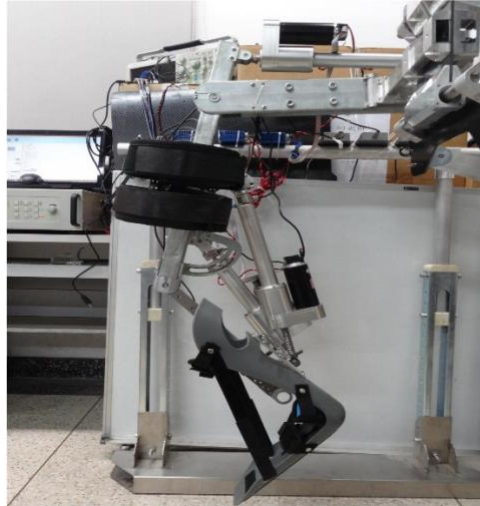

Figure 3: exoskeleton structure

3.4.3.1 Existing Design #1: Sarcos exoskeleton

The structure of the sources exoskeleton is made in a way that the user's limb is interfaced with the exoskeleton containing a stiff metal plate that ensures the user's limb remains stiff while using the device.

3.4.3.2 Existing Design #2: Berkeley exoskeleton

This exoskeleton is structured using springs loaded at the hip and at the ankles whereby the ankles are left to spin (). This project aims at loading springs at the hip and ankle joints too.

3.4.3.3 Existing Design #3: MIT exoskeleton

It is designed in a way that the limb of the user can be easily placed in and also can be easily removed. In this case, the user can be able to put it on and take it off with ease as the exoskeleton's structure allows it. The project aims at designing the exoskeleton with an easier way of wearing and removing it.

4 DESIGNS CONSIDERED

The team considered a number of designs based on the customer and the engineering requirements. These are as shown below.

4.1 Design #3: rotational spring

This design is a rotational spring that has a bearing in it such that it allows the heel to move with a normal human walk. Furthermore, the torsion spring has a very high deflection in case of spiral torsion springs. And has a bearing connected with the torsional spring

Advantage:

- Last for a longer time
 - Can be adjusted easily
- Disadvantage:
- We might add more parts than needed
 - Hard to assemble

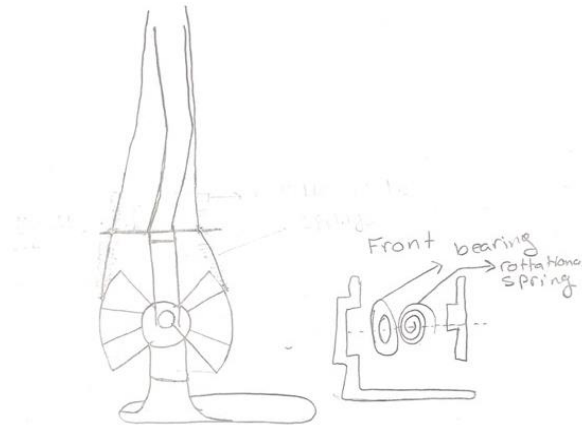

Figure 9: rotational spring

4.3 Design #7: springs connected to the pulley.

For this design, we will not have to redesign the pulley all we have to do is figure out which spring to use. Also, this design will increase the torque.

Advantage:

- Will not change the pulley
- More power efficient

Disadvantage:

- It would do the opposite of what we are aiming for
- Springs are in parallel

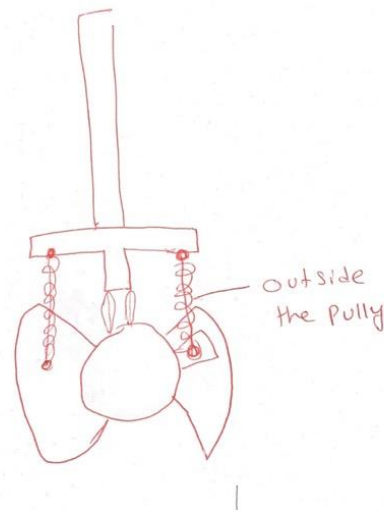

Figure 10: springs connected to the pulley

4.4 Designing of the exoskeleton using all the above designs.

This design will be more flexible for the patient. When the patient moves the spring we also absorb the force while walking, and it has movable plates, so it can be adjusted and have a vertical movement.

Advantages:

- It helps the patient when he slips
- It has an adjustable length

Disadvantages:

- Increasing the design length
- Increasing the weight

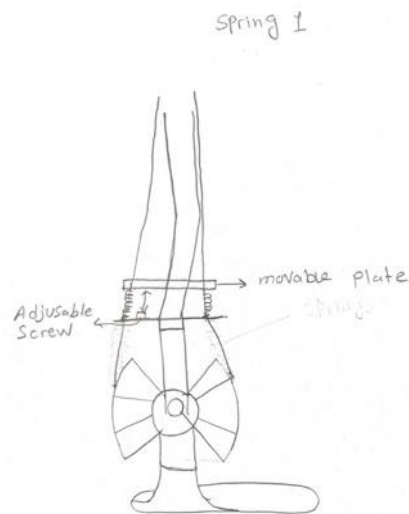

Figure 11: Designing of the exoskeleton using all the above designs

5 Design Selected

Selection of the most appropriate design was based on the customer needs couple with the objectives. More so, since any given engineer would want to use minimal material but come up with a satisfactory product, the design which would see less material being used would be more preferable.

5.1 The rationale for Design Selection

The Project Rationale is a layout of perspectives explaining the foundation of the project. It recognizes the requirement for the product and offers viable options. The team was satisfied with the existing Design #3: MIT exoskeleton design as it met all the conditions of the engineering requirements as well as client specifications. As shown in the Pugh Chart Design 2 is the simplest design, so we chose it to be our datum. The selection was based on the outcome of Pugh matrix that indicated that 3 had the highest number of desirable characteristics such as simplicity and non-invasiveness (Appendix 8.2).

5.2 Design Description

The team decided on using the designs in figure 10 in order to come up with an exoskeleton that can be used individuals of any age group. This can be satisfied by the use of adjustable straps as well as the design being able to be elastic. The use of Decision matrix ensures that the design is functional and meet the requirement. The Decision matrix helped us to choose the best suitable design that will meet the requirement. Furthermore, our analytical and calculated work as shown in (appendix 8.2B) proved that the design will meet the customer requirement.

Table 4: Decision matrix

Criterion	Weight	Design 3		Design 7		Design 10	
		90	38.61	70	30.03	83	35.607
Provide Torque	.429	90	38.61	70	30.03	83	35.607
Specify Material	.166	75	12.45	82	13.612	79	13.114
Spring Location	.132	80	10.56	90	11.88	85	11.22
Noninvasive	.151	90	13.59	85	12.835	80	12.08
Not complicated design	.122	70	8.54	80	9.76	85	10.37
Totals	1		83.75		78.117		82.391
Relative Rank			1		3		2

The visual Impression of the design

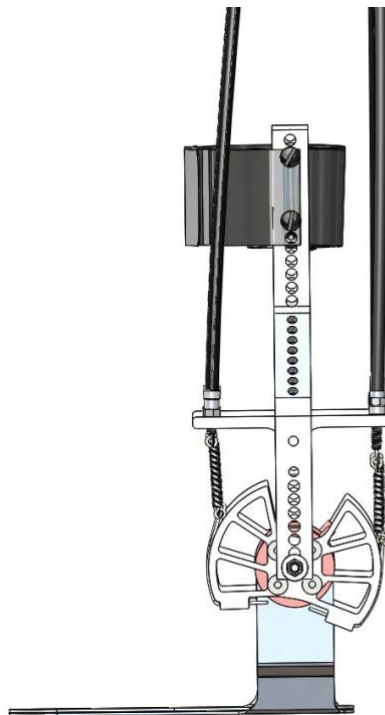

Figure 12: CAD image of the design

6.0 Proposed Design

In this section the team will explain the process in order to build the design. First the team has done the drawing of the exoskeleton design in solid work, second the team will send the CAD package to the machine shop in order to know the cost and time it needs to build each part, expect three parts. The rest of the part are going to be manufacture from prolabs which a website is provided by the client. The three parts which are the motor and the gear box will be order from the company called maximum motors and the bag pack will be given from the Client. Third the team will know the cost and will be filling the papers from NAU's machine shop. Last is receiving the parts individually and attaching them together in the machine shop at NAU. The way in which the team will build the exoskeleton is by separating the work into two parts which are the two lower leg parts and the one back pack part. The two lower leg parts both has an individual plate on the bottom, which is connected to the torque sensor by a shaft and the shaft is connected to the pulley. They will be tied with four screws from each side. The pulley will be attached by two springs with a cable called a fishing cable. This is the two lower leg parts the second part of building process will be the one bag pack part. This bag contains a gear box, motor and attached with the pulley from the lower leg parts. This is the way in order for the team to build the exoskeleton step by step process.

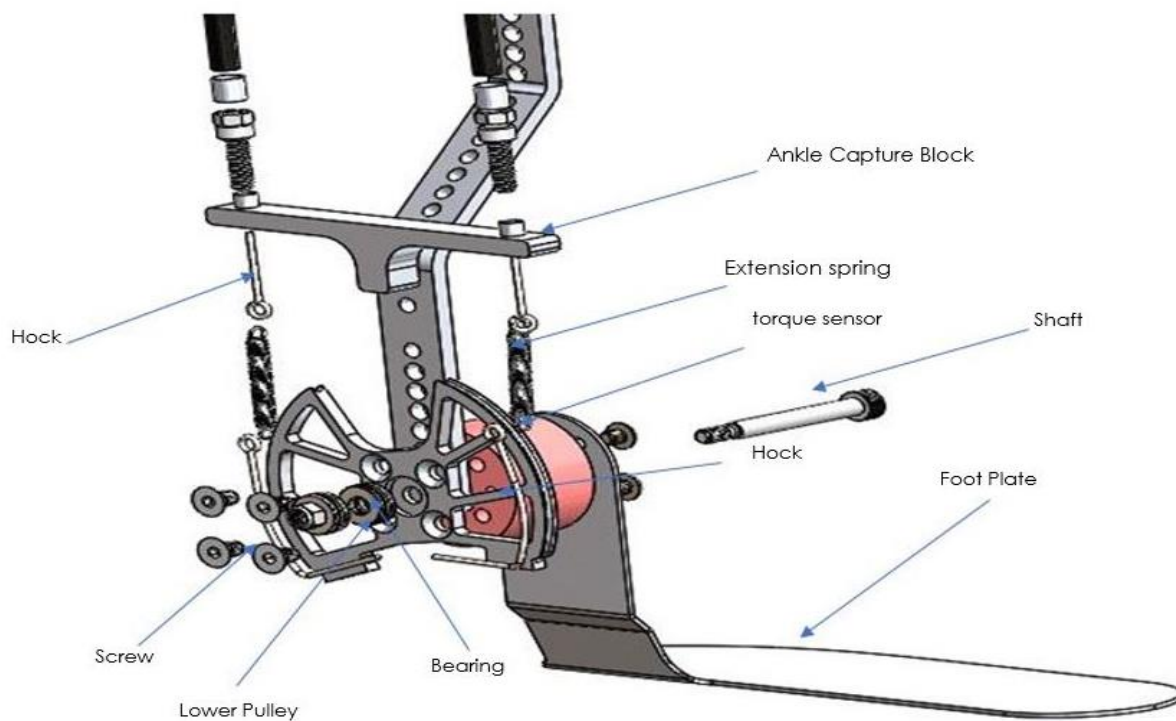

Figure 13: CAD Exploded View

7 IMPLEMENTATION

For the implementation of the project we need to start working on the design of the Exoskeleton for the application of the leg. We have considered different 9 types of the designs. Final design we have proposed is as shown in the figure 1 below:

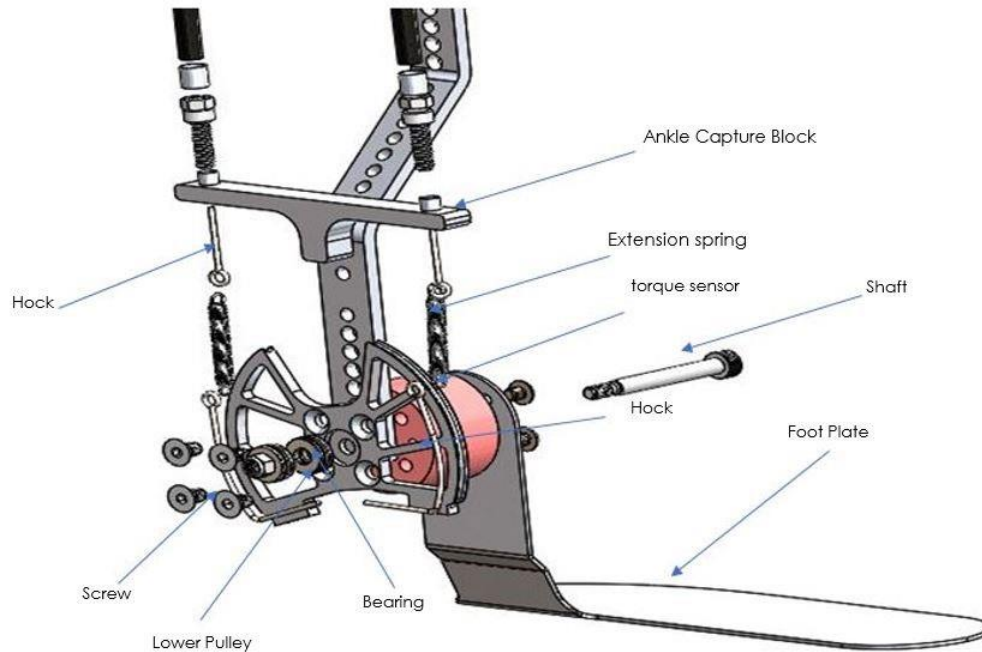

Figure 14: Exploded view of Project Model

As we can see from the Figure 1, it consists of the different components. Total list of the components is listed in the Assembled parts table in the Table 1.

Sr. No.	Assembled parts	MOC (Material of Construction)
1.	Shaft	SS
2	Bearing	SS
3	Foot Plate	SS
4	Ankle Capture Block	SS
5	Extension spring	Spring Steel
6	Lower Pulley	Aluminum
7	Hock	SS
8	Torque Sensor	As per Datasheet

Table 5: Assembled parts

7.1 Manufacturing

For the manufacturing of this project we need to start from the basic components which is ordering and will get component ready from the supplier like torque sensor, Screws, Extension Springs because it takes time for delivery. First, we have ordered the torque sensor. For the torque sensors we needed a reaction type torque sensor. We have selected reaction torque sensors TRT-500 model torque sensor of Make Transducer Techniques from the website of the organization according to our required specification as shown below.

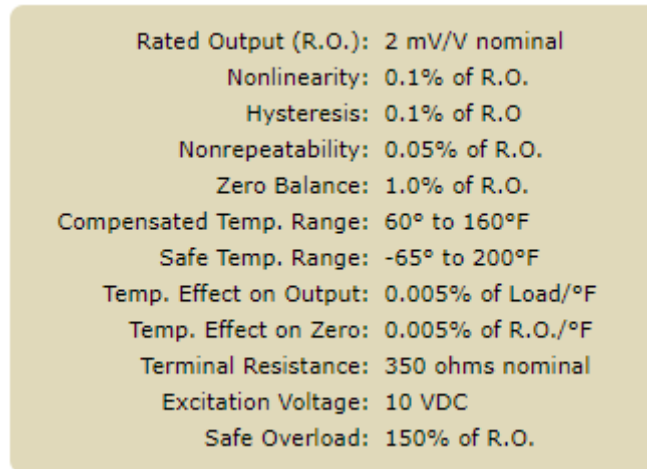

Rated Output (R.O.):	2 mV/V nominal
Nonlinearity:	0.1% of R.O.
Hysteresis:	0.1% of R.O.
Nonrepeatability:	0.05% of R.O.
Zero Balance:	1.0% of R.O.
Compensated Temp. Range:	60° to 160°F
Safe Temp. Range:	-65° to 200°F
Temp. Effect on Output:	0.005% of Load/°F
Temp. Effect on Zero:	0.005% of R.O./°F
Terminal Resistance:	350 ohms nominal
Excitation Voltage:	10 VDC
Safe Overload:	150% of R.O.

Figure 15: Torque Sensor Specifications

After that we have done the ordering of the spring which is going to be used in the Ankle support block and pulley. We have ordered it from a company called Century Spring based on our calculation. Since the T bar and the motor Bracket are the most sensitive and hard parts to be manufacture our client recommended to use protolabs. Which is an online machine shop. The reason that we started ordering the major items as we considered because the need time to be delivered. After that, we started to order the items that arrive fast which is Shaft, Bowden cable, Screws, Bearings, Meatal Sheets and meatal bar...etc. After ordering all of the items, we started with process of manufacturing the leg bar. Also, since we have exceeded our budget our client has provided the pulley and the foot plate.

7.1.1 Ability to be used by people of any age

This project was designed to cater for people who have difficulties in walking and this exoskeleton that has spring torque and uses the spring pulleys to assist in movement. This is achieved by analyzing different dimensions. Such dimensions are;

In the manufacturing which the exoskeleton is meant to be used by people across all age group and of a certain specific weight range that is from the children to the adult and to the old people who faces the challenges of moving around on their feet hence the requirement analysis was conducted before undertaking any manufacturing to meet this customer is requirements.

The second dimensions is mechanical design issues so as that the design is adjustable to be used by people across the different age groups. Adjustability of the exoskeleton is paramount in the manufacturing section in which the limbs, the external frames and the use of thigh belts for adjustability. This is achieved in the design change, in which adjustable belts are used to secure the foot. The material to be used need to be a light weight material and has a high load bearing capability.

7.1.2 Weight of 0.7 kg or less for Patients with 50 lbs-150lbs

This design is to enable people with disability to move around hence the need for the exoskeleton to have a system that is light weight. For this analysis is done to keep the weight at 0.7kg or lower per limb.

7.1.3 Material selection

The material to be used is considered to factor weight reduction for the exoskeleton. Carbon fiber is the preferred material, this is because it has properties such as it is a very high lightweight material and can withstand large loads.

7.1.4 System design

Weight reduction and system efficiency was the essential of the implementation while at the same time maintaining the mechanical properties of the design. The mechanical properties are have to be kept at a specific value, which is the yield strength of the system is to be maintained at 500ksi and the modulus of elasticity (E) at 678ksi. The weight reduction is catered through load modelling and analytical calculations.

7.1.5 Controllers

The exoskeleton has 8 DOF and can be controlled in two ways; through impedance control or the torque control. In this design, the torque control was used. The exoskeleton operates, when the foot plate moves the shaft moves the torque sensor and the pulley. The pulley rotates the cables resulting to the extension springs extending.

7.1.6 Material for the control and actuation activities

The control and actuation activities, the material used have to be quick in response and the system must not load heavily in the structure in which it is mounted. Actuation activities were designed to have less lag and quick control. The motor from the torque is limited and it for the device to work better the torque need to be attained in a very small amount of time.

7.1.7 Bill of materials

The BOM is formulated in regard to the selected material. This bill of materials was prepared after market survey was carried out. The table 1 shows the BOM for the proposed design. This was done after the team contacted a company which gave the team estimated costs. Furthermore, this BOM are all material was purchased from McMaster-Carr.

Table 1. Bill of Materials

Part name	Dimensions	Price
Alloy steel screw	6mm M5X0.8 40mm	3.30
Alloy steel screw	6mm M5X0.8 45mm	6.04
Alloy steel screw	6mm M5X0.8 50mm	6.40
Worm drive clamps	5/16 wide band	6.26
SS ball bearing	6mm shaft diameter	52.44
Roller chain	ISO 04B chain	30.22
Button head hex screw	M5X0.8mm	40.92
Aluminum bar 6063	1/8 x 3/4	11.28
SS corrosion resistant wire	7x7 1/16	8.00

Total= \$174.06

7.2 Design Changes

For the finalization of the design we have faced many problems in the manufacturing and application wise. We have considered 9 different types of design as described below:

To improve the design so as the goal of the project, there are design changes which are made so as to achieve. These changes are made throughout the project process from the beginning till the end. The main problem encountered was the attached to the cost of material to be used to actuate the design.

The exoskeleton system has several iterations to assist in the technology to the individuals with neuromuscular deficiencies. The original design faced with both technical and operational challenges which are weight issues of the exoskeleton which burden the customers and the assembling of the exoskeleton was complex, the strength of the prototype, there were also issues of low-quality built design and implementation, mismatched user and product requirements and functionalities, lack of adjustability and fluidity in response and operations, as well as a barrage of other operational, structural and mechanical deficiencies.

In this research, the parameters of the gait and the variables of the lower limb that will be fundamental to develop the exoskeleton in the physical part as in the mechanical part were analyzed. In addition, the flexion/extension angles of each of the joints were obtained, which can be used to control the mechanism. The T bar used aluminum 6061 t-651 for the structure. This structure allows the design to be withstand weights of up to 150lbs. In addition, the design will include use of thermoplastic material to cover the legs for purposes of improving on the strength of the material, allow for comfort of use, as well as improve on the covering of the legs while in use. Equally important this design is adjustable by moving the sheet of the plastic up and down. Also, the foot plate also is adjustable for different sizes. Moreover, the size of screws was 0.25".

Based on the design, the team seeks to improve ensure that the structure of the design is hard enough to be able to carry a load weight of maximum 150lbs. In addition, the structure toughness and elasticity should be in such a manner that the design remains effective for use and also be long lasting.

Some of the design changes had caused problems for the team which was due to the material which was used at first which cost was high. Also, the team encountered problems in designing the exoskeleton system to be adjustable as demanded by the customer with respect to their requirements. Since the in the hardware review part, the team had accomplished and implemented half of the project at the same time having the team to concentrate on finishing the rest of project to the specifications.

To address this different foot plates had to be created and the thickness of the footplate had to be adjusted. This addressed the weight of the design of the exoskeleton. Plastic sheet materials were used in the project since they have good resistance to chemicals and can withstand large loads. They can wear and fairly hard. The team had printed the leg bar, T bar and the torque sensor using the 3D printing machine and they were attached to the project in order to be fitted on the actual design.

To reduce skin irritation pieces of foam were glued on the plastic sheets. Also, to make the material used to be stronger aluminum sheet were added around the plastic sheet of the shin and thigh areas.

8 Work Cited

- [1] S. Hasegawa, M. Konyo, K. Kyung, T. Nojima and H. Kajimoto, *Haptic Interaction: Perception, devices and applications*. 2015.
- [2] C. Walsh, *Biomimetic design for an under-actuated leg exoskeleton for load-carrying augmentation*. 2006.
- [3] M. Ceccarelli and V. Glazunov, *Advances on Theory and Practice of Robots and Manipulators*. Cham: Springer International Publishing, 2014
- [4] A. Azad, *Adaptive Mobile Robotics: Proceedings of the 15th International Conference on Climbing and Walking Robots and the Support Technologies for Mobile Machines, Baltimore, USA, 23-26 July, 2012*. World Scientific, 2012.
- [5] H. Kawasak, S. Ueki, S. Ito and T. Mouri, "Design and Control of a Hand-Assist Robot with Multiple Degrees of Freedom for Rehabilitation Therapy", *Gifu-u.ac.jp*, 2016. [Online]. Available: https://www.gifu-u.ac.jp/news/news/upload/20140303_IEEEASMEPaper2012.pdf. [Accessed: 14- Oct-2018].
- [6] H. Bleuler, M. Bouri, F. Mondada, D. Pislá, A. Rodic and P. Helmer, *New Trends in Medical and Service Robots*. Cham: Springer International Publishing, 2016.
- [7] K. Mankala, S. Banala and S. Agrawal, "Novel swing-assist un-motorized exoskeletons for gait training", *Journal of NeuroEngineering and Rehabilitation*, vol. 6, no. 1, p. 24, 2009.
- [8] van der Kooij, H. et al. "Compliant Actuation Of Exoskeletons". *Ris.Utwente.Nl*, 2019, <https://ris.utwente.nl/ws/portalfiles/portal/5591352/Kooij06compliant.pdf>. Accessed 20 Jan 2019.

9 Appendix

9.1 Appendix A: Design Considered

i.Design #1: Spring connected to cables.

Here, the connection of the spring and the pulley in order to enable the user to walk with as little difficulty as possible. Furthermore, the springs will be connected to the pulley and will have a shock absorber and will have a rotational angle of 90 degrees. But this design was recently disapproved by our client because the springs are designed as a parallel elastic actuator. The advantages of this design will reduce the torque of the pulley. The disadvantage is that will do the opposite of what is required for us because they are in parallel.

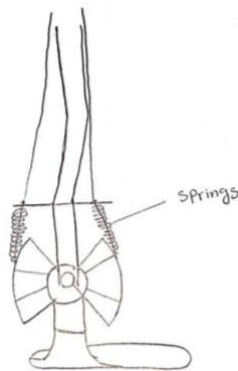

Figure 13: Spring connected to cables

ii.Design #2: spring connected to plated leg.

Here, the spring is connected to the exoskeleton's leg and is supported by another spring. Moreover, this spring will only help the patient to walk in a comfortable way. The disadvantage for this design it will not fit in the patient shoes.

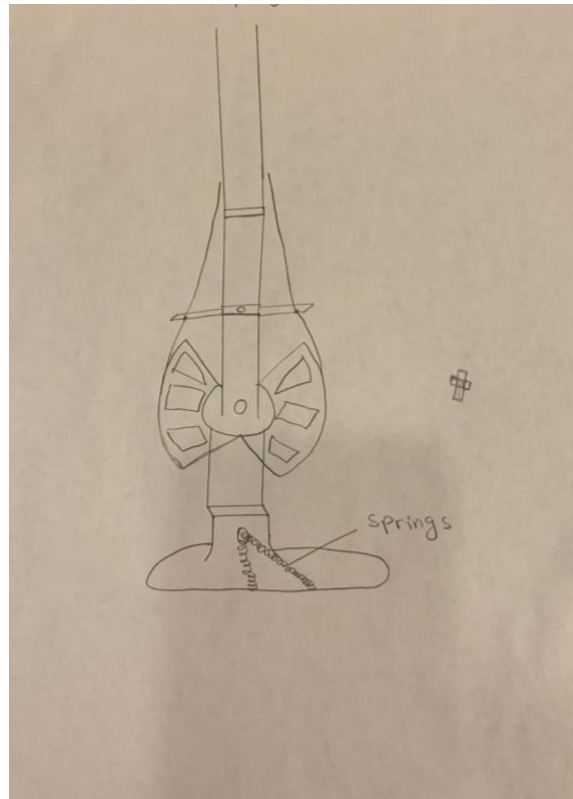

Figure 14: spring connected to plated leg

iii.Design #4: pulley or hip joint design.

This design is changed completely by moving the location of the pulley and adding an additional damping spring assembly this would actually work theoretically. The main issue was we had to change the exoskeleton model. Deservingness may not meet the engineering requirements. Finally, advantages for this is that it will handle more torque than required.

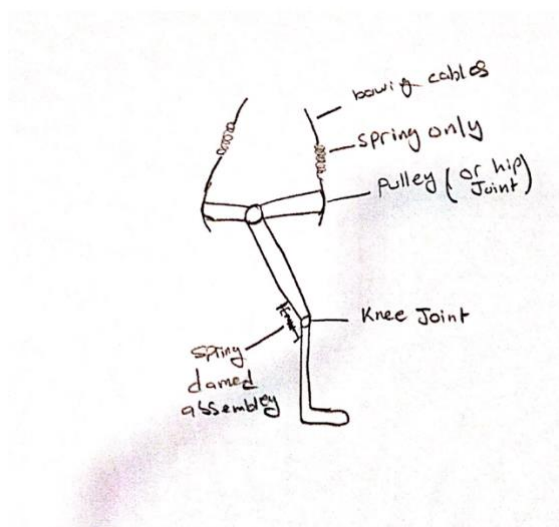

Figure 15:

iv.Design #5: damping spring design

This design was previously the same as the two springs connected to the cables but there would be a fixed plate up and have a moving plate connected to the pulley that would be moving vertically. Furthermore, having a spring damping connected between the fixed plate and the center of the pulley. The advantages of this design are that it has multiple cables that could make the walking of the patient more smoothly. The disadvantages are that we can only have at least two springs.

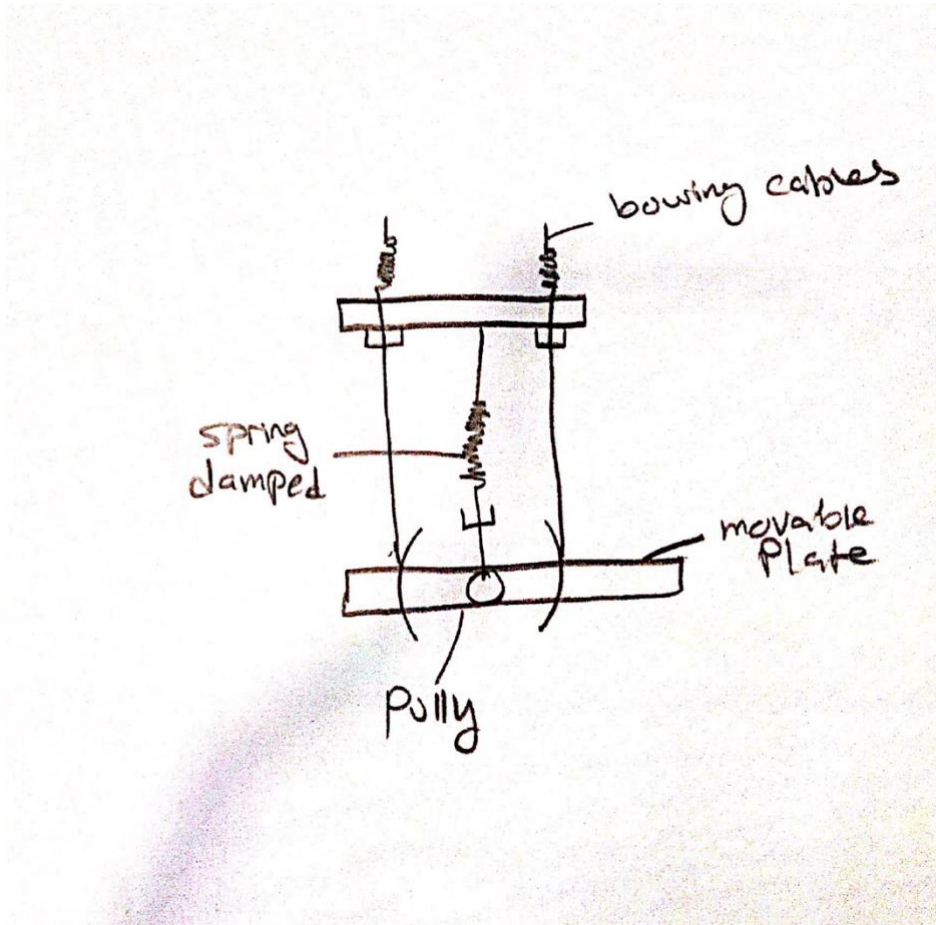

Figure 16: damping spring design

v.Design #6: buckling cables

For this design, we have created this design, so it could absorb the force that comes out of the surface pushed on (Newton first law). It will absorb it by the two fixed springs, and by the damping spring. The Advantages of this design as previously stated that it has the damping spring that will improve the walk of the patient. The disadvantage for this that it may have a parallel elastic actuator which will work opposite that what we are aiming for.

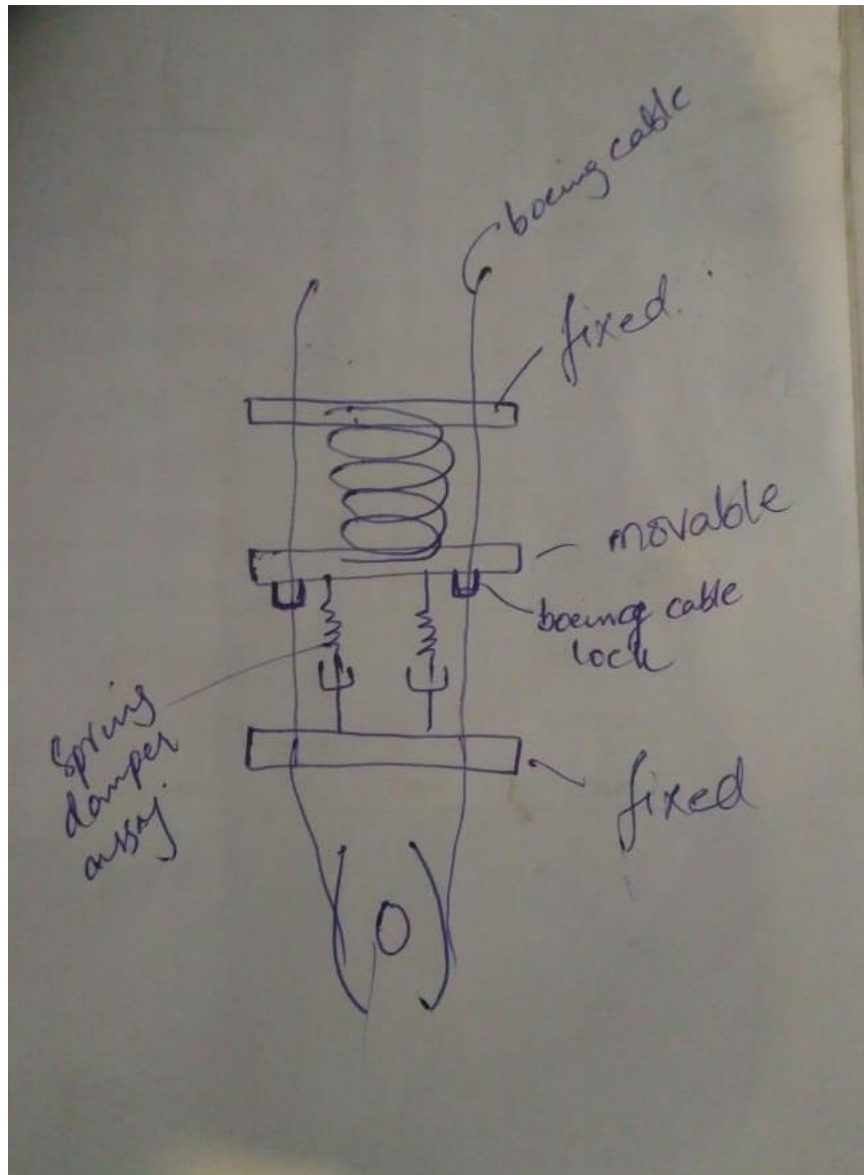

Figure 17: buckling cables

vi.Design #8: Design with straps.

This design had a more complicated way of understanding and implementing and did not match the engineering requirements. Furthermore, the tray that will have a vertical motion only and have a fix horizontal plate finally have an adjustable screw. The advantages for this that it will have adjustable screws that will make the springs move more freely rather than stick to one place. Disadvantages, it might contact the leg.

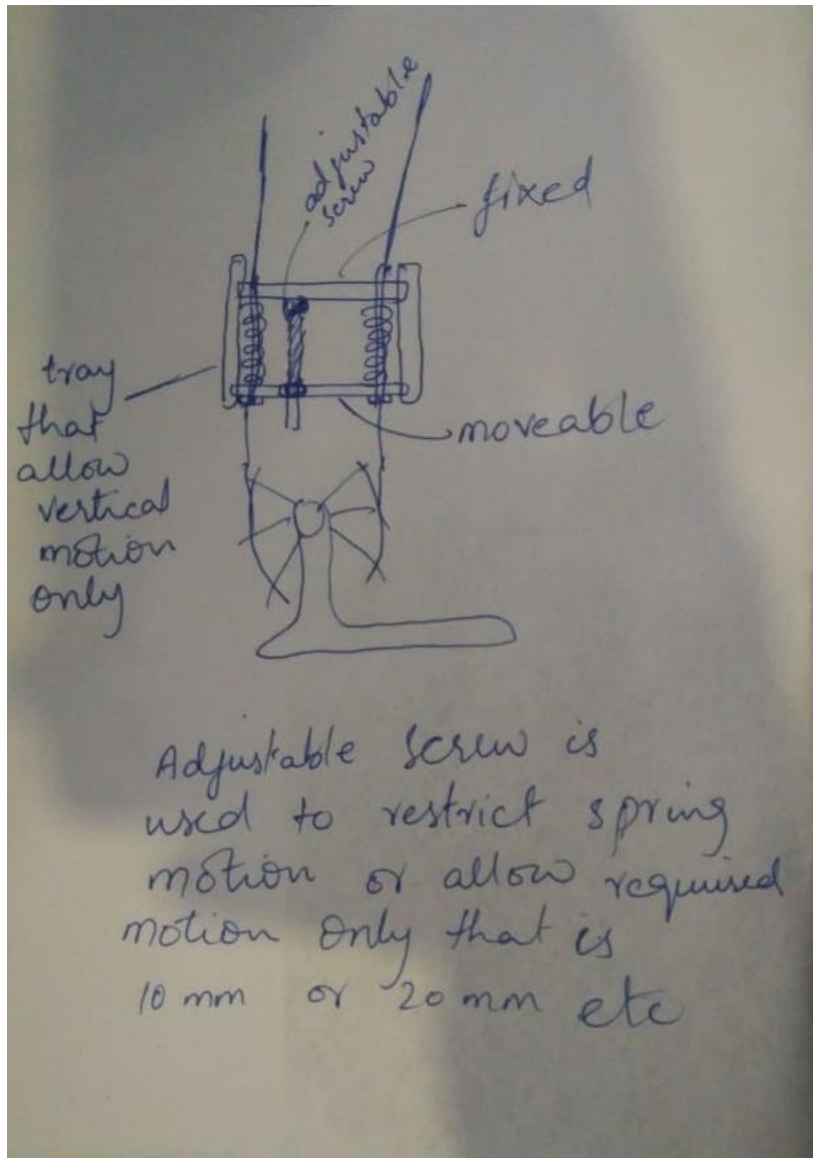

Figure 18: Design with straps

vii.Design #9: Fabric

For this design, we thought about putting the spring above the cable screw, and that will only reduce the motor torque, not the pulley torque.

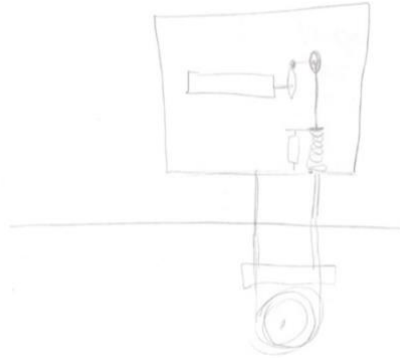

Figure 19: Fabric

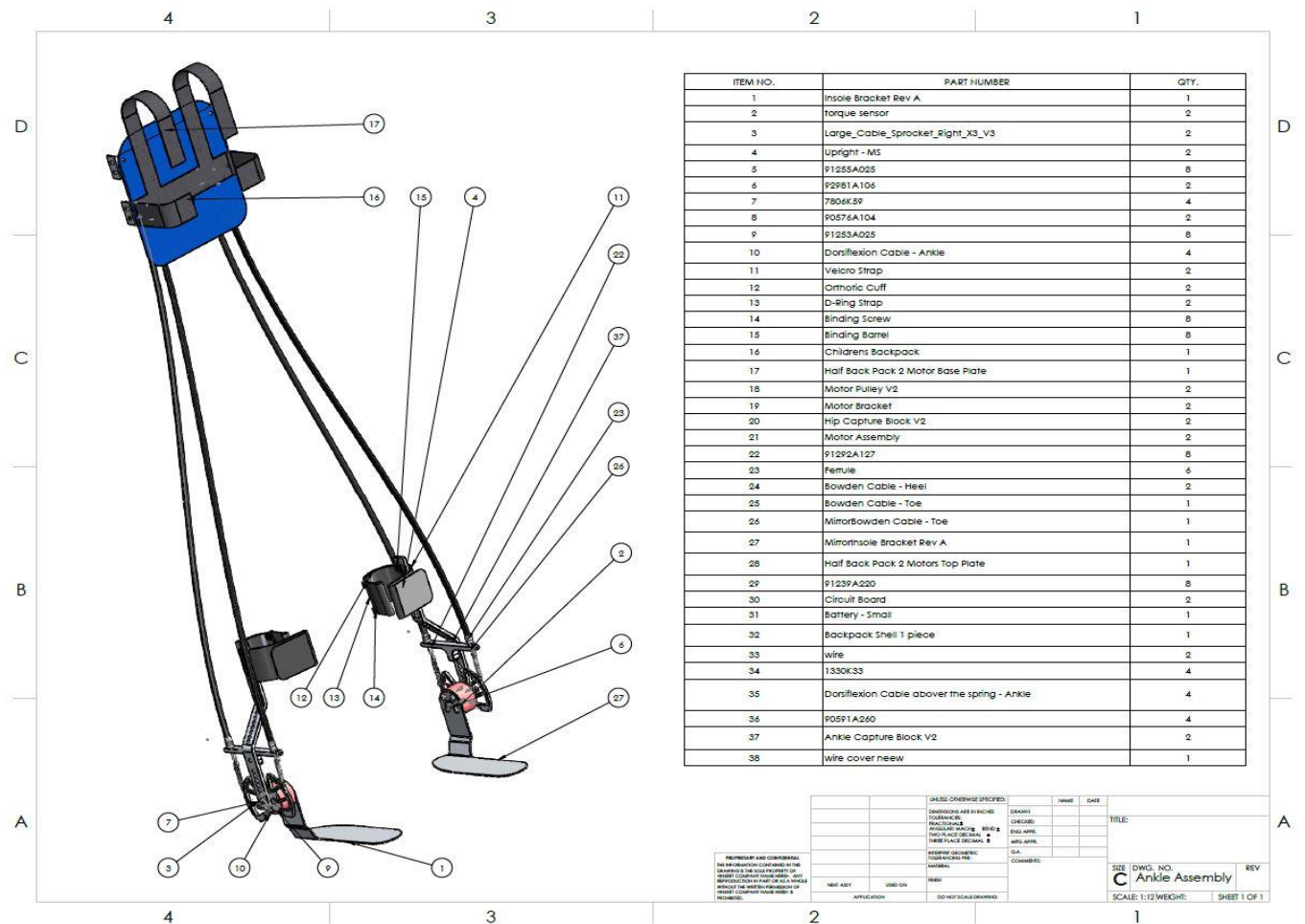

Figure 20: CAD Drawing Sheet

9.2 Appendix B:

Table 5: Pugh Chart

Concept										
Criteria	Design 1	Design 2	Design 3	Design 4	Design 5	Design 6	Design 7	Design 8	Design 9	Design 10
Measure torque	S	D	+	-	S	S	+	+	S	+
Lightweight	-	D	S	S	+	-	S	-	S	-
Clinical gait	-	D	+	+	S	S	+	S	+	+
Noninvasive	S	D	+	S	-	+	+	+	+	+
Simple	S	D	+	S	+	S	-	S	-	-
$\Sigma +$	0	D	4	1	2	1	3	2	2	3
$\Sigma -$	2	D	0	1	1	1	1	1	1	2
ΣS	3	D	1	3	2	3	1	2	2	0

Item	Part Name	Material	Quantity	Unit	Description	Price	Total Price
1	GP2C 1231 (PN: 1466)	High performance per volume and weight unit	1	unit		\$13.45	\$13.45
2	PN: 43275 ESCON 30	Highly efficient control of permanent magnet servomotor brushed DC motor	1	unit		\$137.18	\$137.18
3	PN: 43275 ESCON 30	Highly efficient control of permanent magnet servomotor brushed DC motor	1	unit		\$137.18	\$137.18
4	AM54	Motor Assembly	1	unit		\$170.00	\$170.00
5	RSR-12450	Non-Isolated DC/DC Converters	1	unit		\$6.10	\$6.10
6	15572	Test Holder 2 IN 1 USB HOLDER	1	unit		\$1.15	\$1.15
7	92961A106	Capacitor 1000µF 40V 5% 12.5mm	1	unit		\$3.30	\$3.30
8	92961A106	Capacitor 1000µF 40V 5% 12.5mm	1	unit		\$3.30	\$3.30
9	92961A100	Capacitor 1000µF 40V 5% 12.5mm	1	unit		\$3.04	\$3.04
10	92961A107	Capacitor 1000µF 40V 5% 12.5mm	1	unit		\$4.40	\$4.40
11	92961A107	Capacitor 1000µF 40V 5% 12.5mm	1	unit		\$4.40	\$4.40
12	92961A107	Capacitor 1000µF 40V 5% 12.5mm	1	unit		\$4.40	\$4.40
13	89755K26	Capacitor 1000µF 40V 5% 12.5mm	1	unit		\$1.28	\$1.28
14	8461744	Capacitor 1000µF 40V 5% 12.5mm	1	unit		\$8.00	\$8.00
15	200847	Capacitor 1000µF 40V 5% 12.5mm	1	unit		\$3.32	\$3.32
16	200847	Capacitor 1000µF 40V 5% 12.5mm	1	unit		\$3.32	\$3.32
17	0239420	Capacitor 1000µF 40V 5% 12.5mm	1	unit		\$5.10	\$5.10
18	MG66EXLMMVMD18	Capacitor 1000µF 40V 5% 12.5mm	1	unit		\$38.02	\$38.02
19	N/A	Capacitor 1000µF 40V 5% 12.5mm	1	unit		\$5.39	\$5.39
20	N/A	Capacitor 1000µF 40V 5% 12.5mm	1	unit		\$5.39	\$5.39
21	HEA7ER101	Capacitor 1000µF 40V 5% 12.5mm	1	unit		\$8.32	\$8.32
22	RNA125P	Capacitor 1000µF 40V 5% 12.5mm	1	unit		\$8.89	\$8.89
23	PR110877	Capacitor 1000µF 40V 5% 12.5mm	1	unit		\$4.00	\$4.00
24	PR10806	Capacitor 1000µF 40V 5% 12.5mm	1	unit		\$113.27	\$113.27
25	PR10806	Capacitor 1000µF 40V 5% 12.5mm	1	unit		\$113.27	\$113.27
26	PR10806	Capacitor 1000µF 40V 5% 12.5mm	1	unit		\$189.69	\$189.69
27	PR10806	Capacitor 1000µF 40V 5% 12.5mm	1	unit		\$189.69	\$189.69
Total Cost Estimate:						\$2,402.89	\$862.20

Table 6: BOM

In order to calculate forces on motor pulley we have to start from the foot.

Load on exoskeleton when it is working with person is around 60 kg i.e.

$$m=60 \text{ kg}$$

$$w=mg=60 \times 9.81=588.66 \text{ N (this is when on ankle when foot is placed)}$$

CG of the system is shown in the picture in the assignment based upon that

$$\phi=\tan^{-1}(25/62) = 22^\circ$$

From the fig

$$l=\sqrt{(62^2) + (25^2)} = 67 \text{ mm}$$

And to meet requirement that is

$$\Theta=10^\circ \text{ this is movement in the ankle}$$

Torque at output pulley is around

$$T_{\text{out}} = l \times w \times \sin(\phi+\Theta) = 0.067 \times 588.66 \times \sin(22+10)$$

This gives

$$T_{\text{out}} = 20.9 \text{ Nm}$$

This is the peak torque at ankle pulley or we can say that motor has to overcome this load or you can say peak load. Now we have a gear ratio from pulley system is 3 this we get by dividing pulley diameter by motor output pulley diameter. Since gear ratio between pulleys is 3, and peak torque is 20.9 Nm so the peak torque that the motor produce is given by

$$20.9/3 = 6.96 \text{ Nm this peak motor torque}$$

Now we know that peak torque that the motor can provide is 7Nm which is greater than 6.96Nm so our system will work. One another important point is how much spring should deflect because if deflection is too much then there would be no effect of spring on the other hand if spring stiffness is too low then lag would come into system this means that when motor rotates first spring will deflect and after that pulley will tend to rotate, so it depends upon requirement that is how much deflection we can afford in the system.

2-3 cm deflection in the spring would be enough so that there is not too much lag in the system.

Now we have calculated what are the forces that are coming on cable

Torque produced on the ankle is 20.9 Nm

This torque will transfer force on the cable

$$T=r \times F$$

Where r is pulley radius and F is force produced on cable So, by back solving it we can calculate what are the forces that are produced on the cable so,

$$F = (2 \times 20.63)/0.0765$$

$$F= 546.4 \text{ N}$$

This is the force produced in Bowden cable and spring.

Now maximum deflection produced in the spring is 3 cm

So

$$x=3 \text{ cm}$$

$$k=F/x$$

$$k=18 \text{ KN/m}$$

This is the stiffness of our spring

Now what would be specs of spring

$$N = \frac{(d^4)G}{8 (D^3)k}$$

For 302 Stainless steel

Max shear stress= 517 MPa

and G=69 GPa

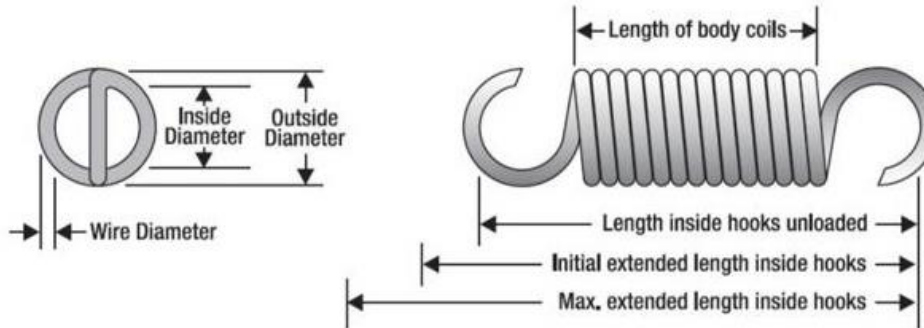

Part Number: 80429

Initial Tension (lb)	2.00
Suggested Max Load (lb)	23.000
Length (in)	1.38
Loop Style	Full Loop
O. D. (in)	0.300
Rate (lb/in)	52.00
Suggested Max Deflection (in)	0.400
Wire Dia (in)	0.055
Length 2	1.38
Standard Finish	None - N

Figure 21: Extension Spring

$$k = \frac{Gd^4}{8D^3n_a}$$

$$G = \frac{E}{2(1+\nu)}$$

G=79Gpa (SS)

Na= Nb + G/E

Na= 60 + 79Gpa/207=60.38

k= F/x

F=538 (produced by toe)

X= 3mm Deflection

Putting the Values

K= 18 (N/m)

$$C = \frac{D}{d}$$

Putting the values

C=2.4/0.5

C=4.8

